

Ride Mower

GTH2254XP

96023000201

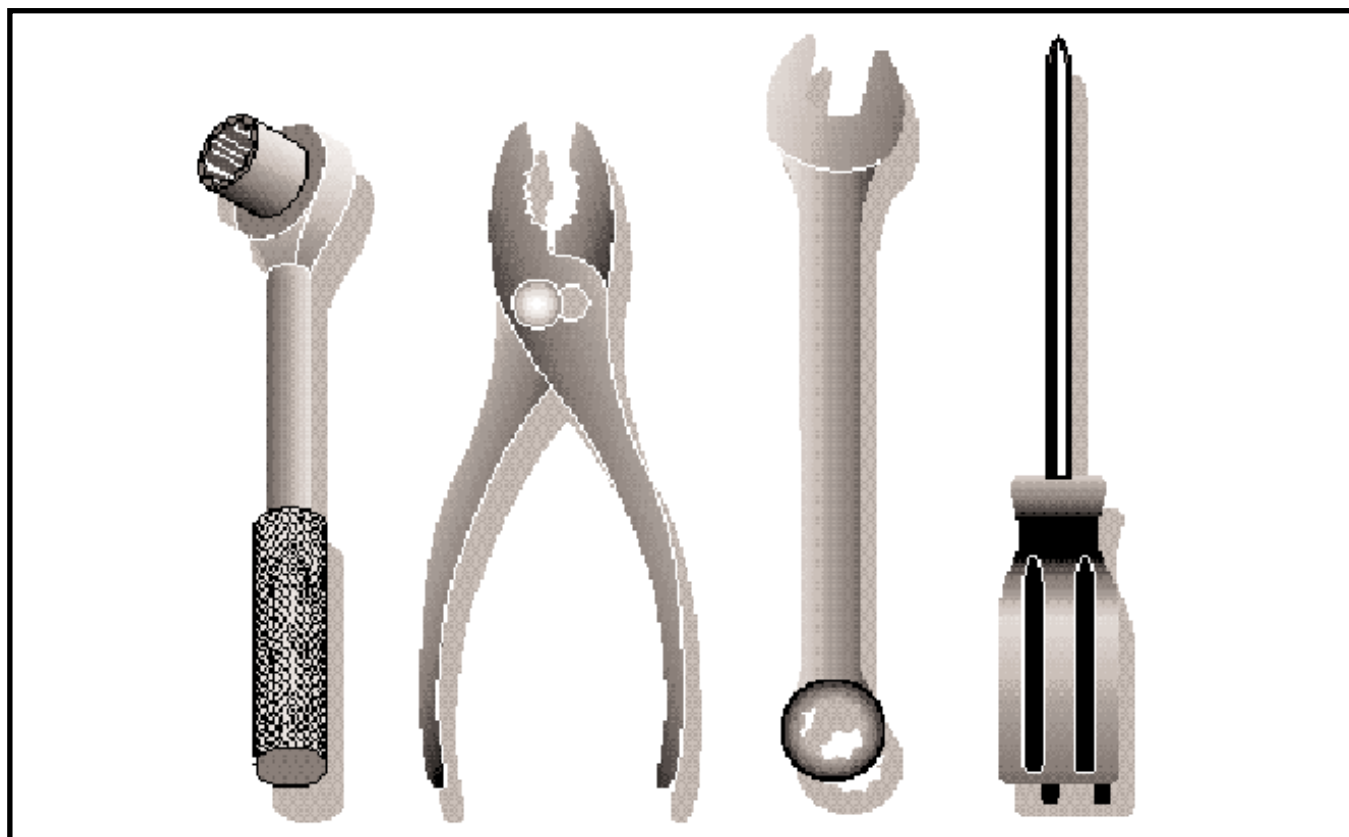

Repair Parts Manual

REPAIR PARTS

TRACTOR - - MODEL NO. GTH2254XP (96023000201) PRODUCT NO. 960 23 00-02

ELECTRICAL

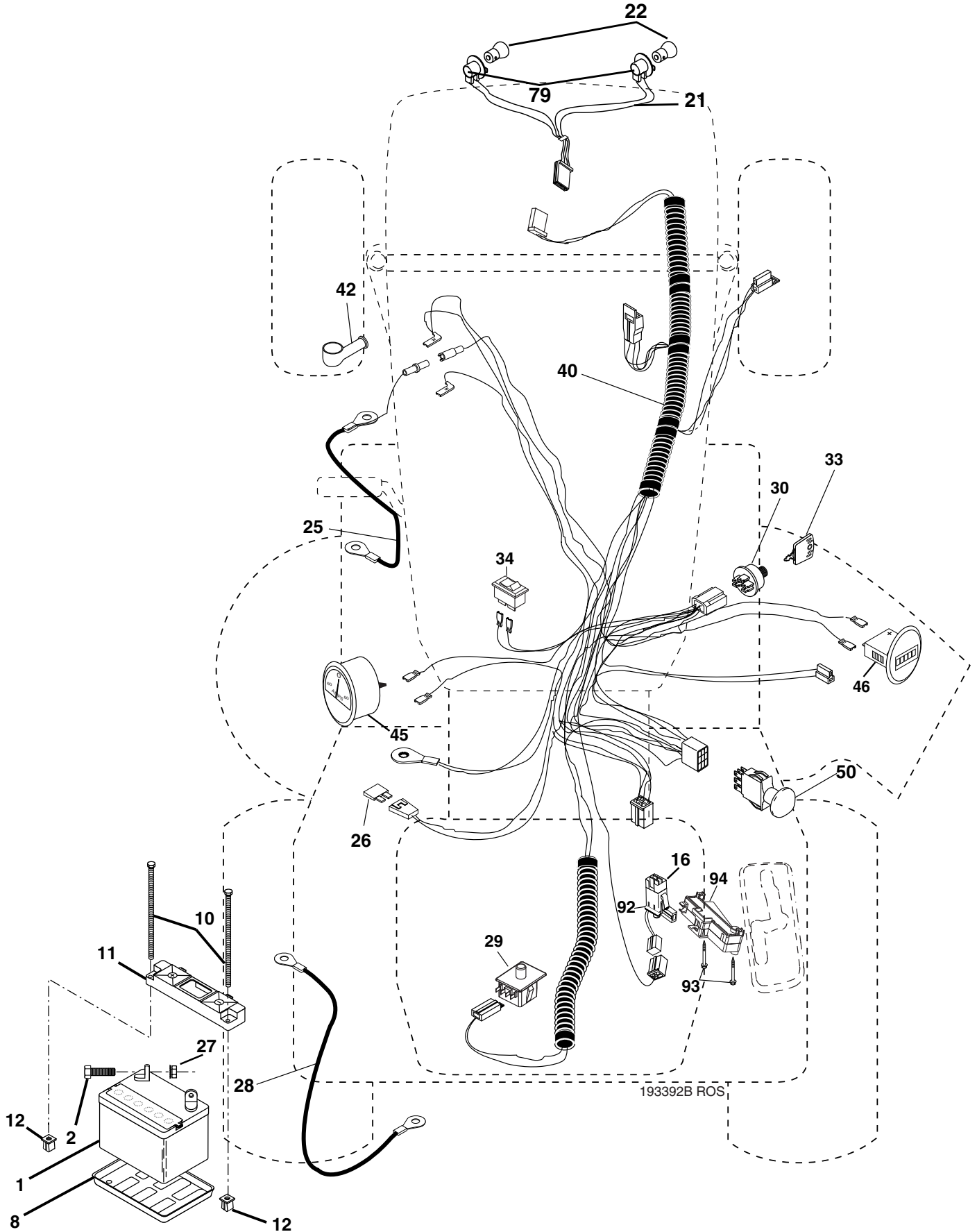

REPAIR PARTS

TRACTOR - - MODEL NO. GTH2254XP (96023000201) PRODUCT NO. 960 23 00-02
ELECTRICAL

KEY NO.	PART NO.	DESCRIPTION
1	532 14 49-27	Battery
2	874 76 04-12	Bolt Hex Head 1/4-20 x 3/4
8	532 12 48-86	Tray, Battery
10	532 14 52-11	Bolt, Battery Front 1/4-20 x 7.5 Zinc
11	532 15 01-09	Holddown Battery Front Mount
12	532 14 57-69	Nut, Push Nylon 1.4" Battery Front
16	532 17 61-38	Switch Interlock Push-In
21	532 17 56-88	Harness Socket Light w/4152J
22	532 00 41-52	Bulb Light
25	532 18 54-61	Cable
26	532 10 88-24	Fuse
27	873 51 04-00	Nut Keps Hex 1/4-20
28	532 17 06-97	Cable Bolt Ground
29	532 19 27-49	Switch, Seat
30	532 19 33-50	Switch, Ign
33	532 14 04-01	Key
34	532 11 07-12	Switch Light/Reset B/B/Red
40	532 19 33-92	Harness Ign.
42	532 15 43-36	Cover, Terminal Red
45	532 17 75-00	Ammeter
46	532 17 75-01	Hourmeter
50	532 17 46-51	Switch, PTO
79	532 17 52-42	Bulbholder Asm
92	532 19 34-65	Harness Pigtail Reverse Switch
93	532 19 25-40	Screw 10-14 x 2.0
94	532 19 18-34	Modual Reverse ROS

NOTE: All component dimensions given in U.S. inches
1 inch = 25.4 mm

REPAIR PARTS

TRACTOR - - MODEL NO. GTH2254XP (96023000201) PRODUCT NO. 960 23 00-02
CHASSIS AND ENCLOSURES

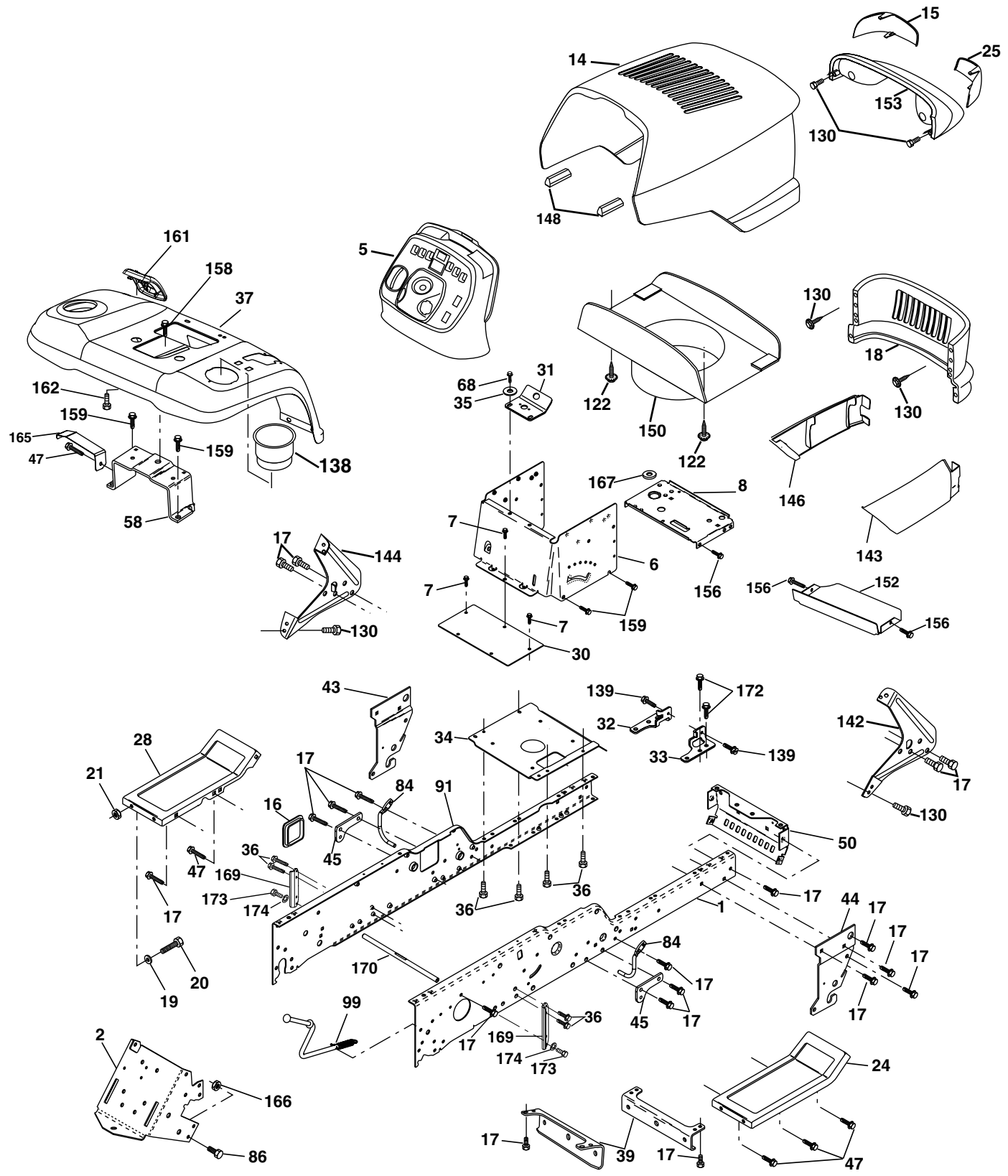

chassis-stealth_51

REPAIR PARTS

TRACTOR - - MODEL NO. GTH2254XP (96023000201) PRODUCT NO. 960 23 00-02 CHASSIS AND ENCLOSURES

KEY NO.	PART NO.	DESCRIPTION	KEY NO.	PART NO.	DESCRIPTION
1	532 18 03-75	Rail, Kit RH	84	532 18 81-64	Upstop 54"
2	532 17 52-82	Drawbar, Gt	86	874 78 07-16	Bolt, Fin Hex 7/16-14 unc
5	532 19 58-86	Dash	91	532 18 03-74	Rail, Kit Lh
6	532 15 78-82	Dash, 1PCS, Lower	99	532 17 71-43	Rod Asm. Bypass
7	817 72 04-08	Screw, Thd Cut 1/4-20 x 1/2	122	532 19 25-12	Screw Hex WSHD 8-18 x 7/8
8	532 18 46-68	Support, Battery	130	532 19 16-11	Screw 10 x 3/4 Single Lead-Hex
14	532 19 00-55	Hood Asm., Pnt	138	532 19 48-69	Cupholder
15	532 16 18-41	Lens LH	139	532 17 18-73	Bolt Shoulder 5/16-18
16	532 12 17-94	Cover, Access	142	532 16 18-97	Bracket Dash Stealth RH
17	817 00 06-12	Screw, 3/8-16 x 3/4	143	532 17 75-86	Skirt Grille RH
18	532 18 28-73	Grille	144	532 16 19-00	Bracket Dash Stealth LH
19	819 13 13-12	Washer 13/32 x 13/16 x 12 Ga.	146	532 17 75-87	Skirt Grille LH
20	874 78 06-16	Bolt, Fin Hex 3/8-16 x 1	148	532 16 46-55	Extrusion Bumper
21	873 80 06-00	Nut, Crownlock 3/8-16	150	532 19 03-09	Duct Heat Hood
24	532 18 10-58	Footrest, RH	152	532 17 79-56	Shield, Browning
25	532 16 18-42	Lens RH	153	532 18 82-12	Lightbox Asm.
28	532 18 10-57	Footrest, LH	156	817 00 05-12	Screw 5/16-18 x 3/4
30	532 14 50-52	Saddle	158	817 67 06-08	Screw 3/8-16 x 1/2
31	532 16 14-19	Bracket Supt 1-pc Vgt Steering	159	817 00 06-12	Screw Hexwsh Thdr. 3/8-16 x 3/4
32	532 16 13-27	Bracket, Frame Pivot Lh	161	532 18 17-87	Cosole Fuel Window
33	532 16 13-26	Bracket, Frame Pivot Rh	162	532 14 24-32	Screw 1/4-1/2 Unc
34	532 17 70-18	Plate Asm Engine Chassis	165	532 18 35-54	Bracket Support Tank
35	819 11 11-16	Washer 11/32 x 11/16 x 16 Ga.	166	873 68 07-00	Nut, Lock Hex 7/16-14 unc
36	817 06 05-12	Screw 5/16-18 x 3/4	167	532 18 46-72	Bushing Snap Nylon 1.250
37	532 19 48-79	Fender, Pnt.	169	532 18 85-98	Bracket
39	532 17 52-78	Bracket, Axle Front	170	532 19 46-67	Rod Bracket Sway Bar
43	532 13 69-39	Bracket, Spnsn Front Lh	172	817 12 06-14	Screw 3/8-16 x .875
44	532 13 69-40	Bracket, Spnsn Front Rh	173	874 78 05-12	Bolt 5/16-18 x 3/4
45	532 18 72-70	Bracket, Susp Arm	174	810 04 05-00	Washer Lock 5/16
47	817 49 06-08	Screw Thdrol 3/8-16 x 1/2			
50	532 17 54-76	Bracket, Chassis Front			
58	532 18 35-69	Bracket Asm., Fender			
68	817 49 05-08	Screw, 5/16-18 x 1/2			

NOTE: All component dimensions given in U.S. inches
1 inch = 25.4 mm

REPAIR PARTS

TRACTOR - - MODEL NO. GTH2254XP (96023000201) PRODUCT NO. 960 23 00-02
GROUND DRIVE

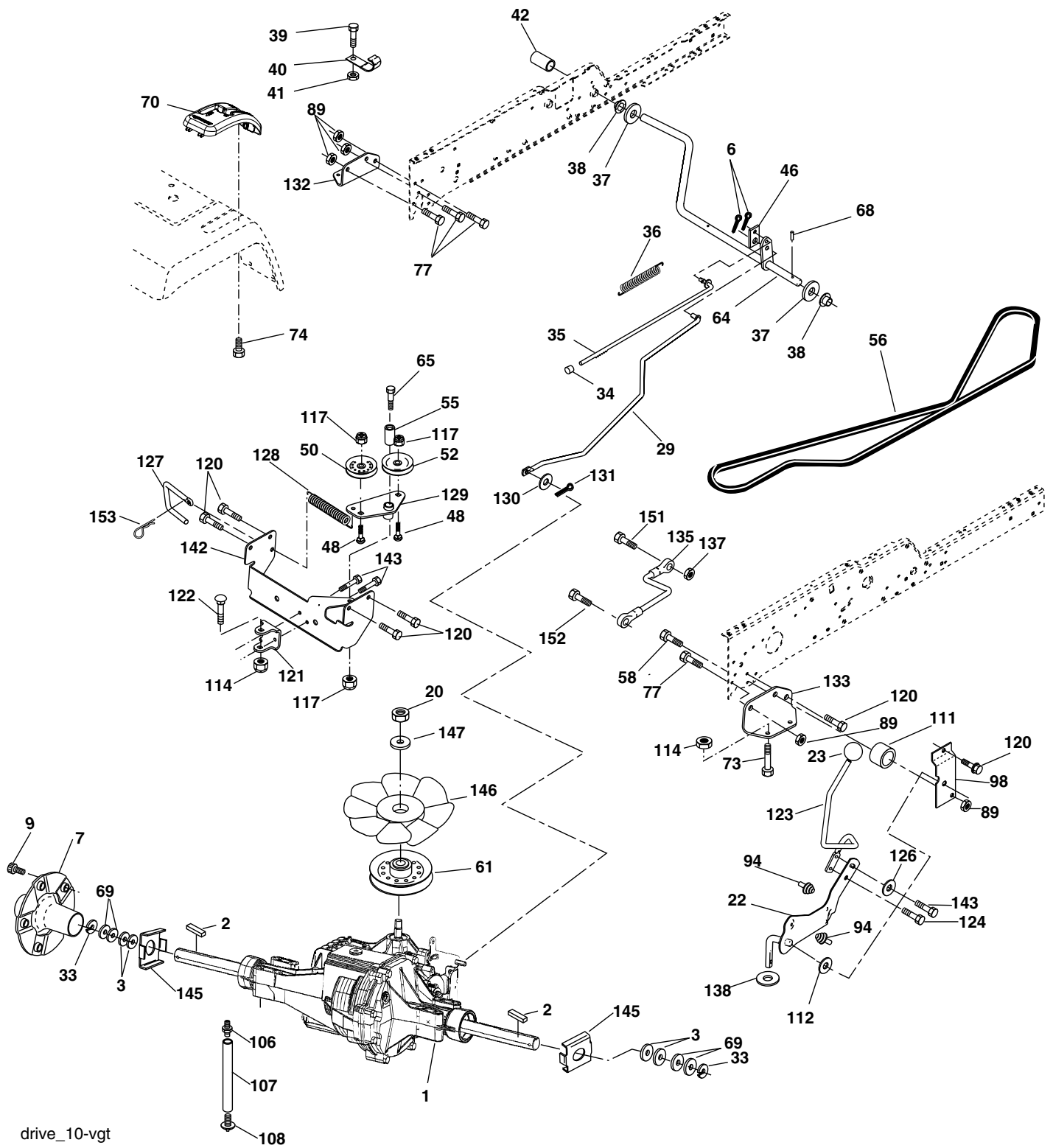

drive_10-vgt

REPAIR PARTS

**TRACTOR - - MODEL NO. GTH2254XP (96023000201) PRODUCT NO. 960 23 00-02
GROUND DRIVE**

KEY NO.	PART NO.	DESCRIPTION	KEY NO.	PART NO.	DESCRIPTION
1	-----	Transaxle Hydro Gear 331-3000 (Order Parts From Transaxle Manufacturer)	94	532 13 38-35	Fastener Christmas Tree
2	532 00 70-70	Key Sq. 1/4 x 1/4 x 2.5	98	532 14 10-04	Bracket Shift
3	532 00 75-63	Washer Thrust	106	532 14 29-18	O-Ring Asm Hydro Gear
6	876 02 04-12	Pin, Cotter	107	532 15 47-39	Line Fuel Hydro 15" VGT
7	532 14 05-07	Wheel, Hub Assembly	108	532 14 29-17	Cap Asm Vent Hydro Gear
9	532 14 00-80	Bolt, Hub	111	532 15 62-40	Spacer Shift Lever VGTH
20	873 94 08-00	Nut	112	532 17 85-58	Washer Nylon High Temp
22	532 18 02-35	Lever Asm Shift	114	873 80 05-00	Nut Lock Hex W/Ins 5/16-18 unc
23	532 14 08-45	Knob	117	873 90 06-00	Nut, Lock Flg. 3/8-16
29	532 17 66-00	Brake, Rod	120	817 00 06-12	Screw 3/8-16 x .75
33	812 00 00-53	Ring E	121	532 17 56-11	Bracket Strap Torque
34	532 07 16-73	Cap, Parking Brake	122	872 01 05-20	Bolt RDHDSQ 5/16-18 unc x 2-1/2
35	532 13 76-48	Rod, Parking Brake	123	532 19 24-38	Rod Shift
36	532 14 94-12	Spring, Drive Ground	124	532 16 54-92	Bolt Shoulder 5/16-18 x .561
37	532 12 17-49	Washer 25/32 x 1-1/4 x 16 Ga.	126	532 16 60-02	Washer SRRTD 5/16 ID x 1.0 x .125
38	532 15 00-35	Nyliner	127	532 17 73-62	Link Control Clutch
39	874 32 10-16	Screw, Fin. #10-24 x 1	128	532 17 66-24	Spring Drive GRND
40	532 17 85-75	Actuator, Interlock VGT	129	532 17 94-73	Bracket Asm Idler Tensioning
41	873 93 10-00	Nut Centerlock 10-24 unc	130	819 13 10-16	Washer 13/32 x 5/8 x 16 Ga.
42	532 12 48-72	Cover, Pedal	131	876 02 03-12	Pin Cotter 3/32 x 3/4
46	532 14 51-70	Retainer, Spring	132	532 17 54-67	Bracket Mtg Hydro 3500 LH VGT
48	872 11 06-14	Bolt Rdhd 3/8-16 x 1.3/4 Gr. 5	133	532 17 54-68	Bracket Mtg Hydro 3500 RH VGT
50	532 13 14-94	Pulley, Idler, Flat	135	532 17 73-64	Link Asm Control Hydro 3500
52	532 12 77-83	Pulley, Idler, Grooved	137	532 12 49-49	Nut Lock 5/16-18 NC Thd.
55	532 10 57-06	Bearing, Idler	138	532 00 13-70	Washer Thrust 5/8 x 1.10 x 1/32
56	532 16 15-97	V-Belt	142	532 17 54-69	Strap Torque HG-3500
58	874 76 07-24	Bolt Fin Hex 7/16-14 x 1-1/2	143	817 00 05-12	Screw Thdrol 5/16-18 x 3/4
61	532 14 39-95	Pulley, Transaxle	145	532 16 31-68	Washer Axle Flange HG-3000
64	532 17 66-01	Shaft, Brake Pedal	146	532 14 04-62	Fan 7" Hydro
65	532 17 96-13	Bolt, Shoulder	147	532 14 13-22	Washer
68	532 00 51-42	Pin, Roll	151	874 76 05-14	Bolt Hex 5/16-18 x 7/8
69	532 12 38-00	Washer	152	532 17 87-05	Bolt Hex 5/16 x 1 W/Patch
70	532 19 48-77	Console Automatic YT/GT	153	532 12 47-88	Spring, Retainer
73	874 49 05-48	Bolt Hex Flghd 5/16-18 x 3 Gr. 5			
74	532 14 24-32	Screw Hex Wsh. Hi-Lo 1/4-1/2			
77	874 78 07-16	Bolt Fin Hex 7/16-14 x 1			
89	873 68 07-00	Nut Crownlock 7/16-14 unc			

NOTE: All component dimensions given in U. S. inches 1 inch = 25.4 mm

REPAIR PARTS

TRACTOR - - MODEL NO. GTH2254XP (96023000201) PRODUCT NO. 960 23 00-02

STEERING ASSEMBLY

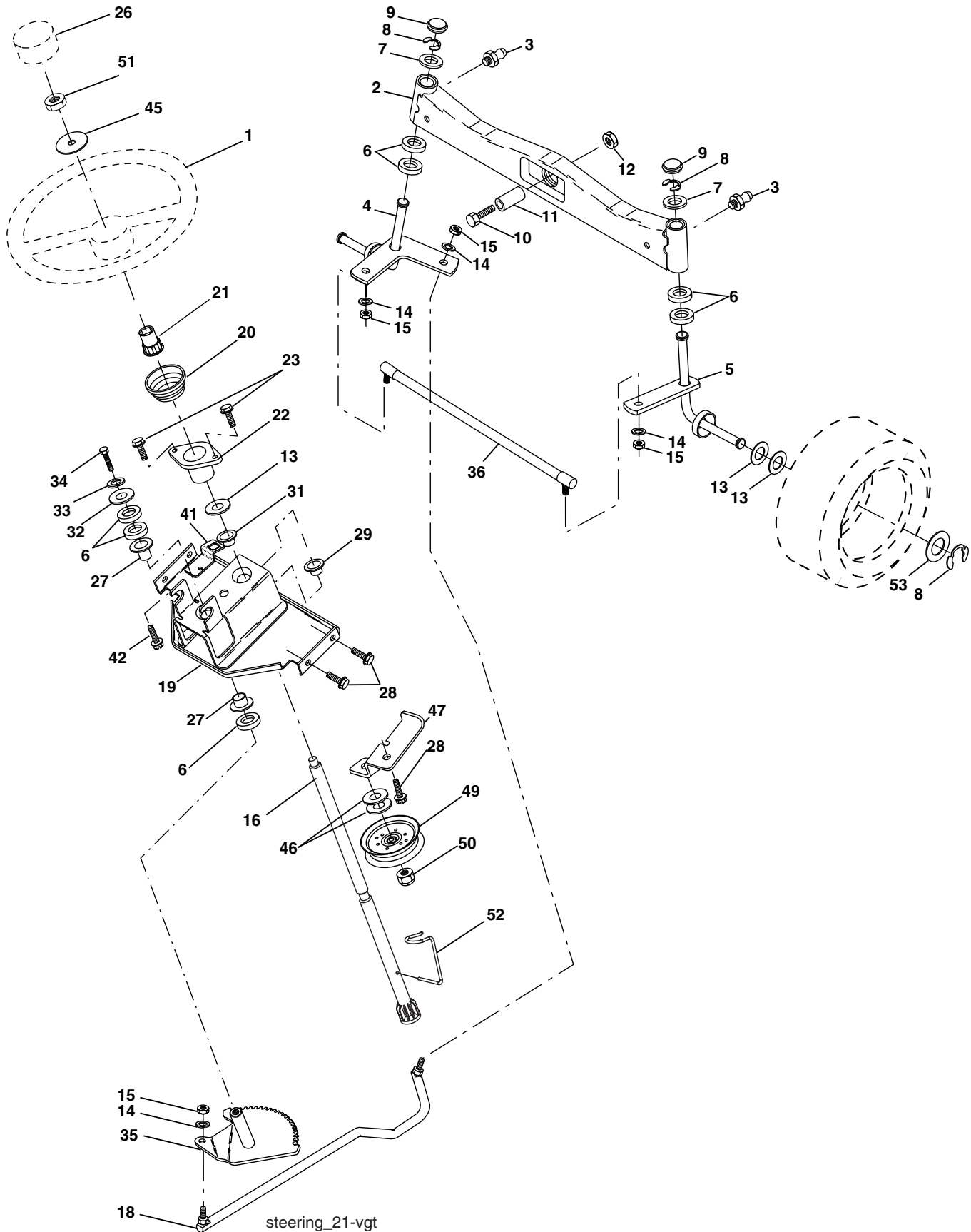

REPAIR PARTS

TRACTOR - - MODEL NO. GTH2254XP (96023000201) PRODUCT NO. 960 23 00-02
STEERING ASSEMBLY

KEY NO.	PART NO.	DESCRIPTION
1	532 19 36-51	Wheel, Steering
2	532 17 85-57	Axle Asm., Front
3	532 18 32-26	Fitting, Grease
4	532 16 18-49	Spindle Asm, LH
5	532 16 18-48	Spindle Asm., RH
6	532 12 49-31	Bearing, Race Thrust Harden
7	532 12 17-48	Washer 25/32 x 1-5/8 x 16 Ga.
8	812 00 00-29	Ring, Klip #T5304-75
9	532 12 12-32	Cap, Spindle
10	874 78 10-44	Bolt, Fin Hex 5/8-11 x 2-3/4
11	532 13 65-18	Spacer Brg Axle Front 1.570
12	873 90 10-00	Nut, Lock Flange 5/8-11 unc
13	532 12 17-49	Washer 25/32 x 1-1/4 x 16 Ga.
14	810 04 06-00	Washer, Lock Hvy Hlcl Spr 3/8
15	873 54 06-00	Nut Crownlock 3/8-24
16	532 18 68-14	Shaft Asm., Steering
18	532 18 77-99	Draglink, Vgt
19	532 15 60-11	Support Asm., Steering Vgt
20	532 17 75-92	Boot Steering
21	532 18 67-37	Adapter, Wheel Steering
22	532 15 51-05	Bushing, Strg.
23	532 15 29-27	Screw
26	532 19 36-52	Cap , Wheel Steering
27	532 12 49-37	Bearing, Col. Strg.
28	817 00 06-12	Screw 3/8-16 x 3/4
29	532 10 42-39	Bearing, Flange
31	532 13 81-36	Bushing, Nyliner Snap
32	819 11 16-10	Washer 11/32 x 1 x 10 Ga.
33	810 04 05-00	Washer, Lock Hvy Hlcl Spr 5/16
34	874 78 05-12	Bolt, Hex Hd 5/16-18 x 3/4
35	532 18 70-39	Gear, Sector Steering
36	532 18 67-99	Tie Rod
41	532 15 52-46	Bracket Switch Inerlock VGT97
42	817 49 05-08	Screw 5/16-18 x 1/2
45	819 18 38-12	Washer 9/16 ID x 2-3/8 OD 12 G Zin
46	819 13 16-10	Washer 13/32 x 1 x 10 Ga.
47	532 17 94-71	Bracket Asm. Idler
49	532 17 58-20	Pulley Idler Flat
50	873 90 06-00	Nut Lock Flg 3/8-16 unc
51	873 94 08-00	Nut Hex Jam Toplock 1/2-20 unf
52	532 17 55-53	Clip Steering .750
53	532 18 89-67	Washer Harden .793 x 1.63 x 060

NOTE: All component dimensions given in U.S. inches
1 inch = 25.4 mm

REPAIR PARTS

TRACTOR - - MODEL NO. GTH2254XP (96023000201) PRODUCT NO. 960 23 00-02
ENGINE

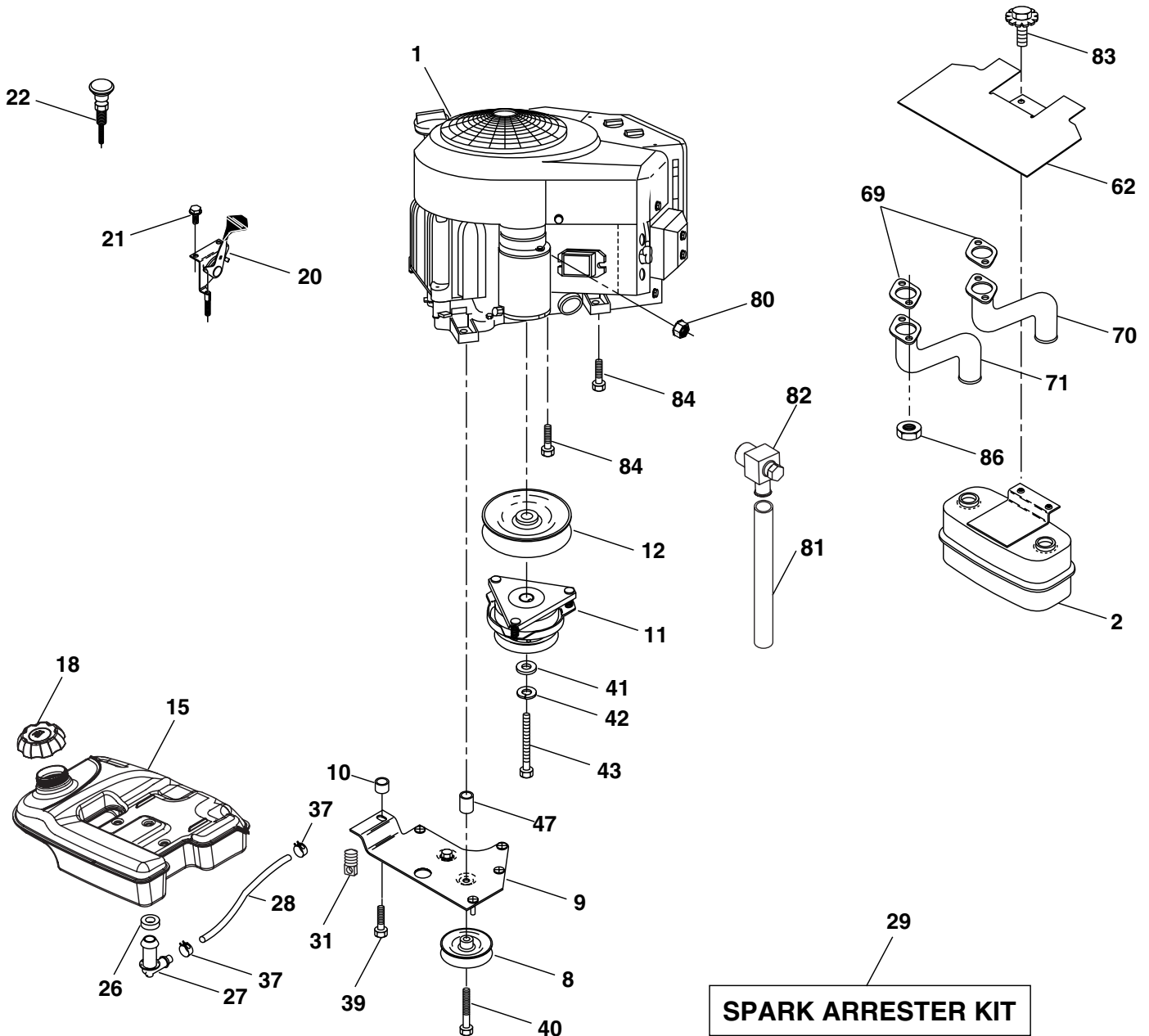

engine-kawasaki_3 vgt

REPAIR PARTS

TRACTOR - - MODEL NO. GTH2254XP (96023000201) PRODUCT NO. 960 23 00-02
ENGINE

KEY NO.	PART NO.	DESCRIPTION
1	-----	Engine Kawa, Model No. FH641V(Order parts from engine manufacturer)
2	532 14 97-23	Muffler Side
8	532 12 13-61	Pulley V-Idler
9	532 17 77-48	Keeper Asm. Belt Engine VGT
10	532 17 52-87	Bushing
11	532 17 93-35	Clutch Electric
12	532 14 39-96	Pulley Engine VGT Elect Clutch
15	532 17 91-15	Tank Fuel Rear 5.0
18	532 18 18-03	Cap Fuel
20	532 17 81-47	Control Throttle
21	532 19 16-11	Screw 10 x 3/4 Single Lead Hex
22	532 18 95-41	Control Choke
26	532 12 49-52	Bushing
27	532 13 92-77	Stem Tank Fuel
28	532 12 47-03	Fuel Line
29	532 13 71-80	Spark Arrester Kit
31	532 14 50-06	Clip Push-In Hinged
37	532 12 34-87	Clamp Hose
39	817 49 06-36	Screw TT 3/8-16 x 2-1/4 unc
40	817 49 06-64	Screw TT 3/8-16 x 4 unc
41	532 12 61-97	Washer 1-1/2 OD X 15/32 ID X .250
42	810 04 07-00	Washer Lock 7/16
43	532 17 99-53	Bolt Hex 7/16-20 x 3.75 Gr. 5
47	532 17 52-88	Bushing
62	532 17 62-52	Shield Heat Muffler
69	532 17 81-51	Gasket
70	532 17 57-66	Tube Exhaust LH
71	532 17 57-67	Tube Exhaust RH
80	532 16 33-05	Nut Flange M8-1.25
81	532 14 84-56	Oil Drain Tube
82	-----	Valve Drain Oil (Order parts from engine manufacturer)
83	532 17 18-77	Bolt 5/16-18 unc x 1-3/4 W/Sems
84	817 06 06-24	Screw 3/8-16 x 1-1/2
86	532 18 43-62	Nut Hex Flange Toplock M8-1.25

NOTE: All component dimensions given in U.S. inches
1 inch = 25.4 mm

For engine service and replacement parts, call the toll free number for your engine manufacturer listed below:

Briggs & Stratton	1-800-233-3723
Kohler Co.	1-800-544-2444
Tecumseh Products	1-800-558-5402
Honda Engines	1-800-426-7701
Kawasaki	1-949-460-5688

REPAIR PARTS

TRACTOR - - MODEL NO. GTH2254XP (96023000201) PRODUCT NO. 960 23 00-02
SEAT ASSEMBLY

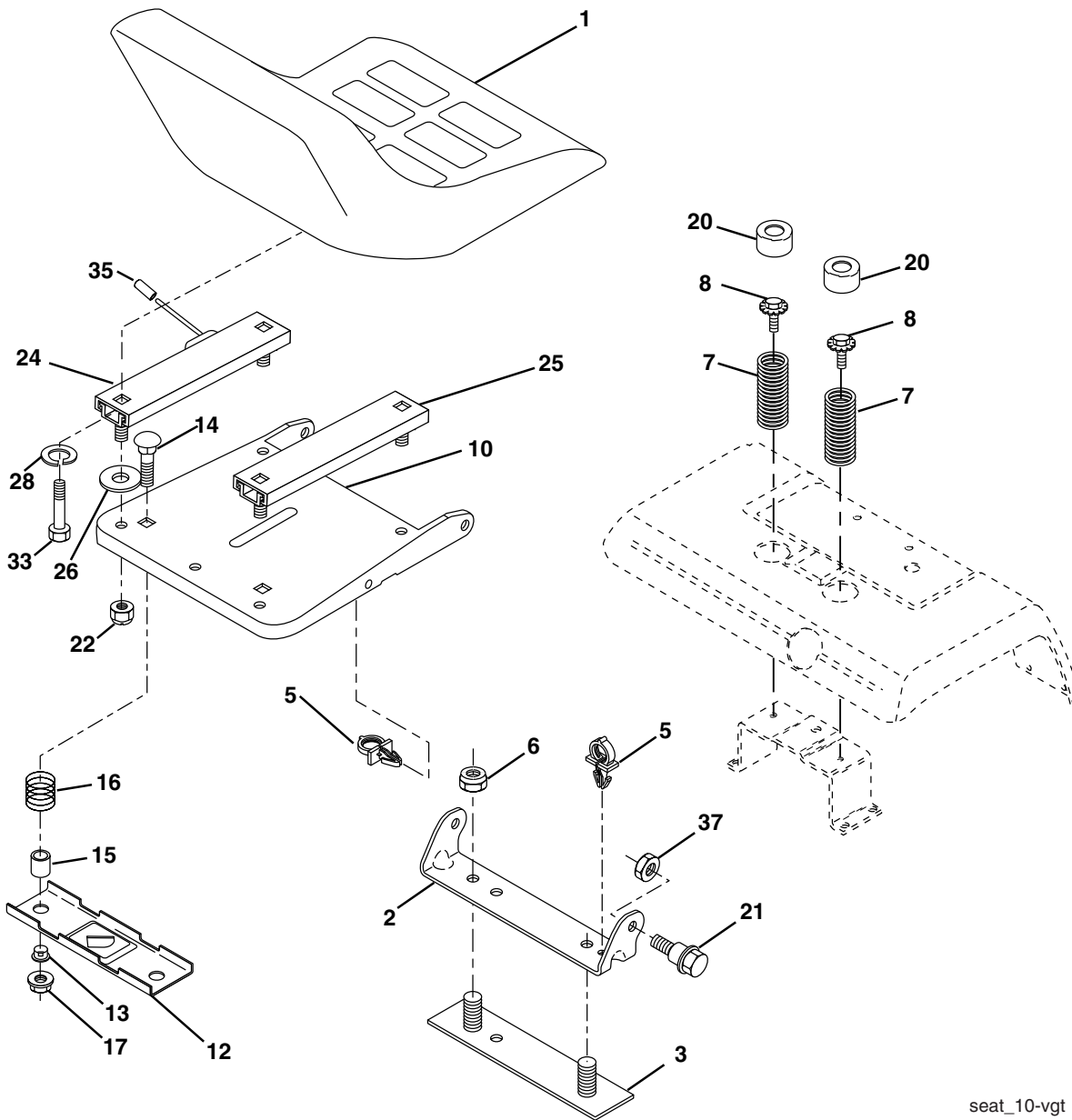

seat_10-vgt

KEY NO.	PART NO.	DESCRIPTION
1	532 18 87-15	Seat
2	532 14 05-51	Bracket, Pivot Seat
3	532 14 06-75	Strap Asm Fender
5	532 14 50-06	Clip, Push In Hinged
6	873 80 06-00	Nut, Crownlock 3/8-16
7	532 12 41-81	Spring, Seat Cprsn
8	532 17 18-77	Bolt 5/16-18 Unc x 3/4
10	532 18 24-93	Pan, Seat
12	532 17 46-48	Bracket, Mounting Switch
13	532 12 12-48	Bushing, Snap
14	872 05 04-12	Bolt, Carriage 1/4-20 x 1-1/2
15	532 12 12-49	Spacer, Split
16	532 12 37-40	Spring, Cprsn

KEY NO.	PART NO.	DESCRIPTION
17	532 12 39-76	Nut, Lock 1/4 Lge Flg Gr. 5
20	532 12 42-38	Cap Spring Seat
21	532 17 18-52	Bolt, Shoulder 5/16-18
22	873 68 05-00	Nut Crown Lock 5/16-18
24	532 17 79-46	Track Slide Seat LH
25	532 17 79-47	Track Slide Seat RH
26	819 11 10-12	Washer 11/32 x 5/8 x 12 Ga.
28	810 01 05-00	Washer Split
33	874 78 05-12	Bolt Fin Hex 5/16-18 x 3/4
35	532 17 84-26	Cap Vinyl
37	873 80 05-00	Nut, Crownlock 5/16-18

NOTE: All component dimensions given in U.S. inches
1 inch = 25.4 mm

REPAIR PARTS

TRACTOR - - MODEL NO. GTH2254XP (96023000201) PRODUCT NO. 960 23 00-02
DECALS

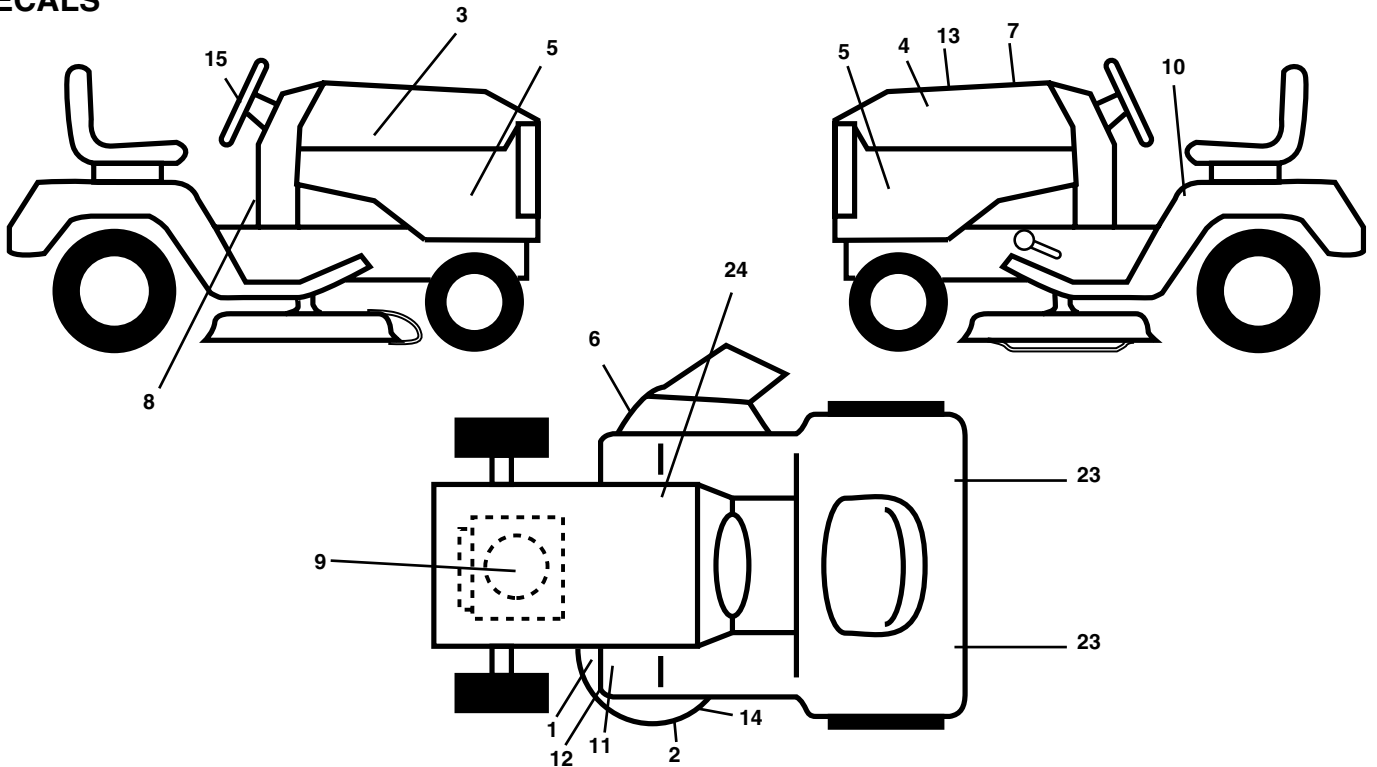

KEY NO.	PART NO.	DESCRIPTION
1	532 17 85-02	Decal, Deck Caution
2	532 17 84-82	Decal, Deck Hvy Duty
3	532 18 89-47	Decal, Hood RH
4	532 18 89-48	Decal, Hood LH
5	532 18 88-89	Decal, Side Panel
6	532 17 05-63	Decal, Warning
7	532 18 09-41	Decal, Cust. Resp.
8	532 19 38-65	Decal, Operator
9	532 17 85-64	Decal, Engine
10	532 15 71-40	Decal, Danger
11	532 18 12-53	Decal, Foot Rest

KEY NO.	PART NO.	DESCRIPTION
12	532 19 30-63	Decal, MWR DCK Upstop
13	532 19 43-65	Decal, Replacement
14	532 18 82-98	Decal, V-Belt Schematic
15	532 18 89-25	Decal, Ins. Strg Whl
23	532 10 62-02	Reflector, Taillight LH/RH
24	532 14 50-05	Decal, Btry Dngr/Psn
--	532 16 69-60	Decal, Drawbar
--	532 18 19-17	Pad Footrest RH
--	532 18 19-16	Pad Footrest LH
--	532 19 64-96	Manual, Owners (English)
--	532 19 64-97	Manual, Owners (French)

WHEELS & TIRES

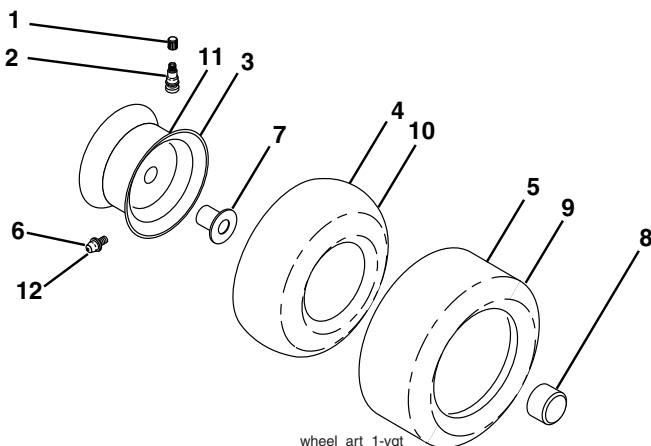

KEY NO.	PART NO.	DESCRIPTION
1	532 05 91-92	Cap, Valve, Tire
2	532 06 51-39	Stem, Valve
3	532 14 45-09	Rim Assembly, Front
4	532 00 81-34	Tube, Front (Service Item Only)
5	532 10 62-30	Tire, Front
6	532 12 49-57	Fitting, Grease
7	532 12 49-59	Bearing, Flange (Front Wheel Only)
8	532 17 50-39	Cap, Hub
9	532 10 55-88	Tire, Rear
10	532 00 71-54	Tube, Rear (Service Item Only)
11	532 14 45-10	Rim Assembly, Rear
12	532 12 48-60	Fitting, Grease
--	532 14 43-34	Sealant, Tire (10 oz. Tube)

NOTE: All component dimensions given in U.S. inches
1 inch = 25.4 mm

REPAIR PARTS

TRACTOR - - MODEL NO. GTH2254XP (96023000201) PRODUCT NO. 960 23 00-02
LIFT ASSEMBLY

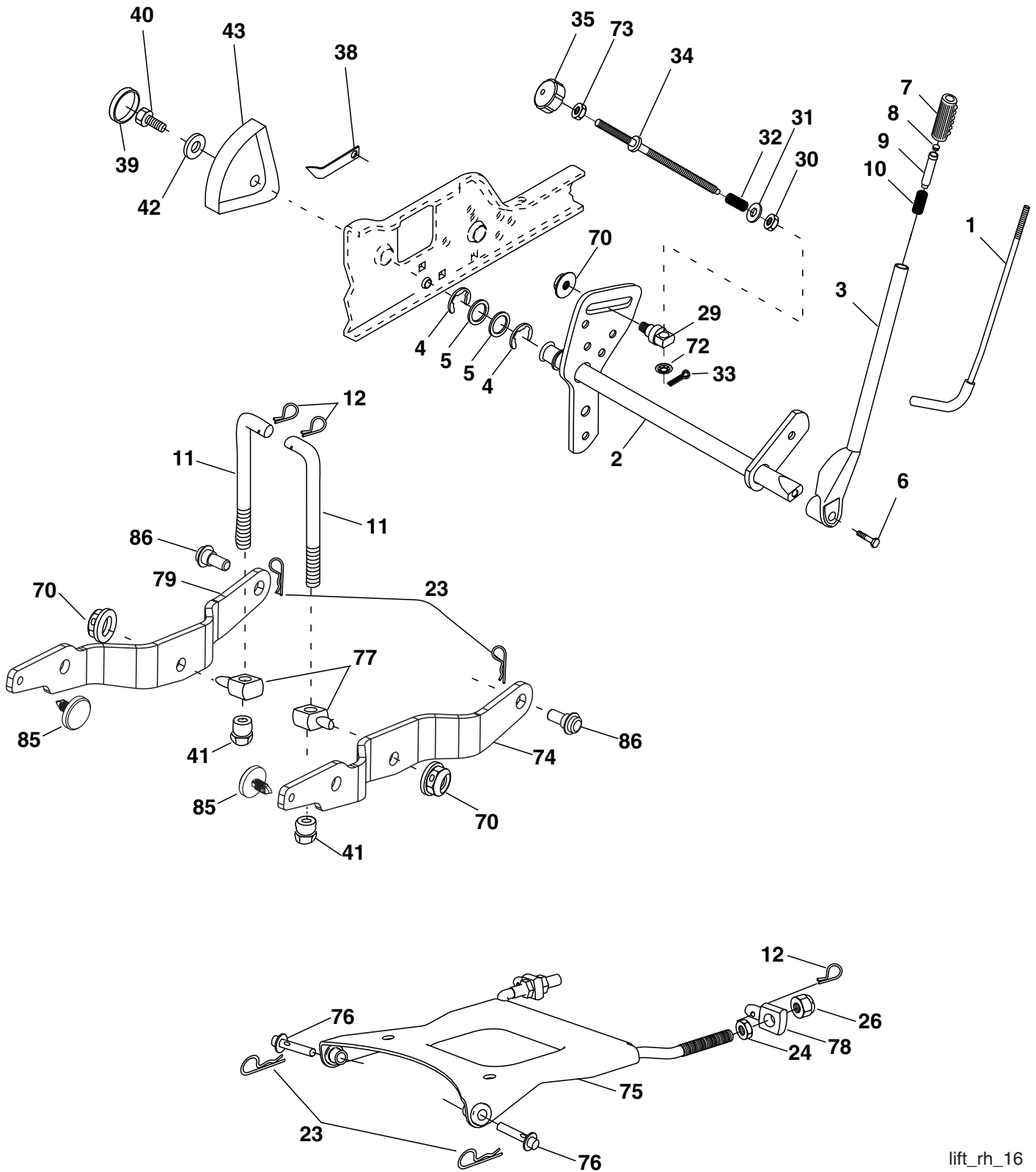

lift_rh_16

REPAIR PARTS

TRACTOR - - MODEL NO. GTH2254XP (96023000201) PRODUCT NO. 960 23 00-02
LIFT ASSEMBLY

KEY NO.	PART NO.	DESCRIPTION
1	532 12 10-06	Rod Asm., Lever
2	532 18 00-45	Shaft Asm., Lift Vgt
3	532 15 91-89	Lever Asm., Lift Rh
4	812 00 00-22	E-Ring Truarc #5133-87
5	819 29 20-16	Washer 29/32 x 1-1/4 x 16 Ga.
6	871 11 06-24	Bolt, Fin Hex 3/8-16 x 1-1/2
7	532 12 56-31	Grip, Handle
8	532 12 45-26	Button, Plunger
9	532 12 23-64	Plunger, Lever Lift
10	532 18 38-94	Spring 0.62 OD x 2.125
11	532 17 53-75	Link Lift
12	532 16 35-52	Retainer, Spring
23	532 12 46-70	Retainer, Spring
24	873 35 08-00	Nut, Jam Hex 1/2-13 unc
26	873 80 08-00	Nut, Lock W/Wsh 1/2-13 unc
29	532 15 02-33	Trunnion Infin Height
30	532 11 08-07	Nut, Special
31	819 13 10-16	Washer 13/32 x 5/8 x 16 Ga.
32	532 13 71-50	Spring, Compression Inf Hgt
33	876 02 03-08	Pin, Cotter 3/32 x 1/2
34	532 13 71-67	Rod, Adj Lift
35	532 13 80-57	Knob, Inf 3/8-16 unc
38	532 15 50-97	Pointer Height Indicator
39	532 12 39-35	Plug, Hole Blk. 1.485/1.515 Dia.
40	817 06 05-16	Screw 5/16-18 x 1
41	532 17 59-94	Nut, Crownlock 3/8-24
42	819 11 24-10	Washer 11/32 x 1-1/2 x 10 Ga.
43	532 12 39-34	Scale, Indicator Height
70	532 14 52-12	Nut Hex Flange Lock
72	532 11 04-52	Nut Push Phos & Oil
73	873 35 06-00	Nut, Hex Jam 3/8-16 unc
74	532 18 72-77	Arm Suspension Rear RH
75	532 17 58-05	Plate, Asm, Susp, Front
76	532 17 55-60	Pin Flange
77	532 17 62-05	Trunnion
78	532 17 56-89	Trunnion, Front, Susp
79	532 18 72-76	Arm, Suspension Rear LH
85	532 18 90-13	Insert Wear
86	532 18 85-28	Bolt Shoulder

NOTE: All component dimensions given in U.S. inches
1 inch = 25.4 mm

REPAIR PARTS

TRACTOR - - MODEL NO. GTH2254XP (96023000201) PRODUCT NO. 960 23 00-02
MOWER DECK

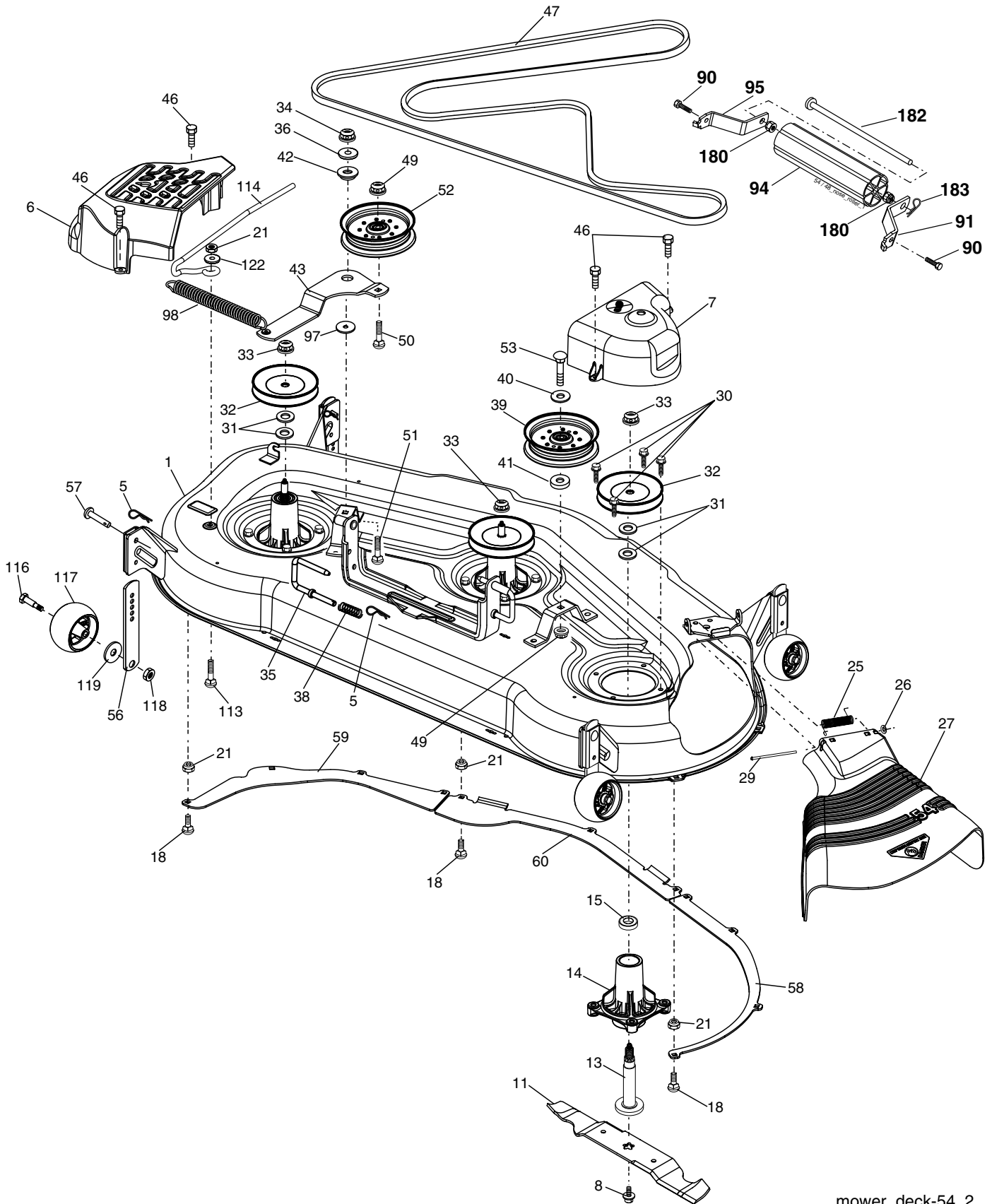

mower_deck-54_2

REPAIR PARTS

**TRACTOR - - MODEL NO. GTH2254XP (96023000201) PRODUCT NO. 960 23 00-02
MOWER DECK**

KEY NO.	PART NO.	DESCRIPTION	KEY NO.	PART NO.	DESCRIPTION
1	532 19 68-38	Deck Weldment Mower	51	872 11 06-10	Bolt 3/8-16 x 1-1/4 Gr. 5
5	532 12 46-70	Retainer Spring	52	532 18 84-60	Pulley Idler clutching
6	532 18 72-97	Cover Mandrel LH	53	874 78 06-36	Bolt Fin Hex 3/8-16 unc x 2-1/4
7	532 18 81-87	Cover Mandrel RH	56	532 15 59-86	Bar Pnt Adj.
8	532 17 43-65	Bolt 7/16 Asm. Blade	57	532 15 69-41	Pin Head Rivet
11	532 18 72-54	Blade Standard	58	532 18 73-42	Baffle Right
13	532 18 72-91	Shaft Asm. w/Lower Bearing	59	532 18 73-44	Baffle Left
14	532 18 72-81	Mandrel Housing	60	532 18 76-07	Baffle Center
15	532 11 04-85	Bearing, Ball, Mandrel	90	874 76 05-16	Bolt 5/16-18 x 1
18	872 14 05-05	Bolt Carr 5/16-18 x 5/8	91	532 18 05-35	Bracket Asm N Roller RH
21	873 68 05-00	Nut, Crownlock 5/16-18 unc	94	532 17 60-66	Roller Nose 48"
25	532 17 81-02	Spring Torsion	95	532 18 05-34	Bracket N Roller LH
26	532 11 04-52	Nut, Push	97	819 13 32-10	Washer Hardened
27	532 18 89-38	Deflector Shield	98	532 18 72-82	Spring Clutch Drive
29	532 13 14-91	Rod, Hinge	113	872 11 05-08	Bolt Rdhd Sqnk 5/16-18 unc x 3/4
30	532 17 39-84	Screw Thd Roll	114	532 18 75-56	Rod Tension Relief
31	532 18 76-90	Washer, Spacer Mower Vented	116	532 19 34-06	Bolt, Shoulder
32	532 17 34-36	Pulley, Mandrel	117	532 17 48-73	Gauge Wheel
33	532 17 83-42	Nut, Flg. Top Lock Cntr. 9/16	118	873 93 06-00	Nut, Centerlock 3/8-16 unc
34	873 68 06-00	Nut	119	819 12 14-14	Washer 3/8 x 7/8 x 14 Ga.
35	532 18 86-35	Pin Suspension Rear	122	532 18 75-57	Bushing Tension Relief
36	819 13 13-16	Washer 13/32 x 13/16 x 16 Ga.	180	873 80 05-00	Nut 5/16-18
38	532 18 86-57	Spring Compression	182	532 17 91-27	Rod Roller Nose Narrow
39	532 18 72-84	Pulley, Idler, Stationary	183	532 16 35-52	Retainer Spring
40	819 13 22-03	Washer 13/32 x 1-3/8 x 3 Ga.	--	532 18 72-92	Mandrel Asm. Service
41	819 13 13-12	Washer 13/32 x 13/16 x 12 Ga.	--	532 19 60-99	(Includes Key Nos. 13-15 and 33)
42	532 12 20-52	Spacer, Retainer			Replacement Mower, Complete
43	532 19 62-16	Arm, Idler			(Std. deck order separately nose
46	532 13 77-29	Screw, Thdroll. 1/4-20 x 5/8			roller components key nos. 90,
47	532 19 12-73	V-Belt, Mower, Secondary			91, 94, 95, 180, 182, 183)
49	873 90 06-00	Nut, Lock Flg. 3/8-16 unc			
50	872 11 06-16	Bolt, Carr. 3/8-16 x 2			

NOTE: All component dimensions given in U.S. inches
1 inch = 25.4 mm